

SPEC SHEET

PRODUCT DESCRIPTION

- PARKER 72 Double Basin with Quartz Stone counter top
- Wall mount cabinet with BLUM mounting hardware
- V shaped legs available in matt black, brushed nickel, polished chrome, and brushed gold finish
- Cabinet is available in Matte White, Rock gray, Natural Walnut, Black Elm, and Brushed White Oak
- Hardwood plywood construction
- Soft close and full extension drawers
- Glass and wood dividers on the top drawers
- Aluminum hardware available in Matte Black, Brushed Nickel, Polished Chrome, and Brushed Gold finish
- 3cm Quartz Stone counter top available in White and Alabaster color
- Lotus undermount porcelain basins with square shape in white (with overflow hole)
- Basin depth is 5.5" (including top thickness)
- Quartz back and side splash are optional

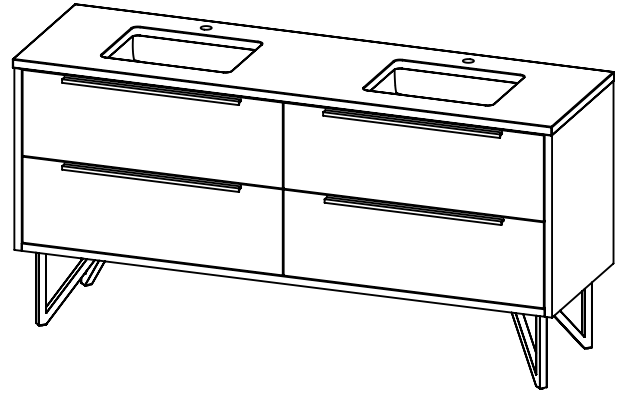

ROUGHING-IN DIMENSIONS

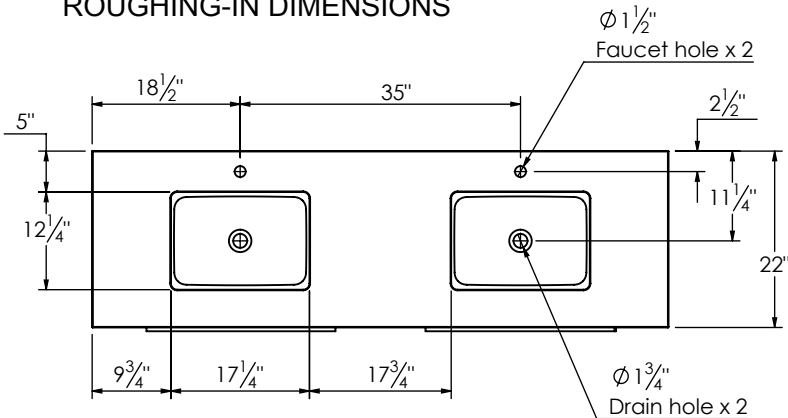

TOP VIEW

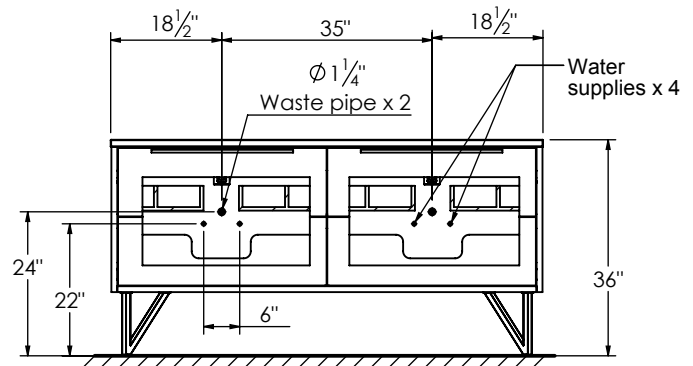

ROUGH PLUMBING

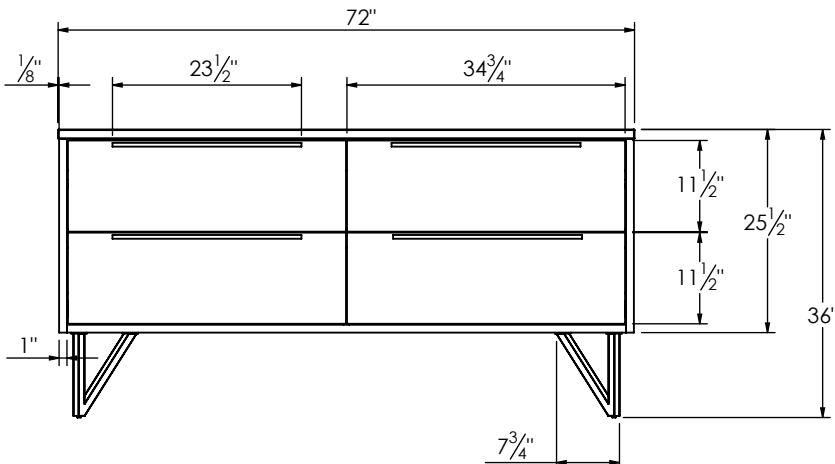

FRONT VIEW

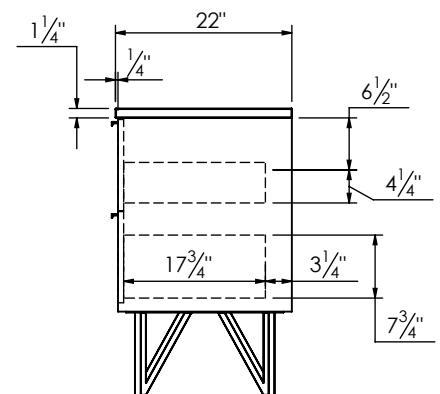

SIDE VIEW