

## SPEC SHEET

### PRODUCT DESCRIPTION

- PARKER 49 Vanity with Quartz Stone counter top
- Wall mount cabinet with BLUM mounting hardware
- Cabinet is available in Matte White, Rock gray, Natural Walnut, and Black Elm
- Hardwood plywood construction
- Soft close and full extension drawers
- Glass and wood dividers on the top drawer
- Aluminum hardware available in Matte Black, Brushed Nickel, Polished Chrome, and Brushed Gold finish
- Quartz stone counter top available in White and Calacatta color
- Lotus undermount porcelain basin with square shape in white (with overflow hole)
- Basin depth is 5" (including top thickness)
- Quartz back and side splash are optional

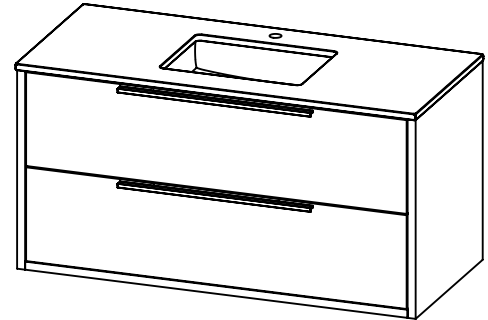

### ROUGHING-IN DIMENSIONS

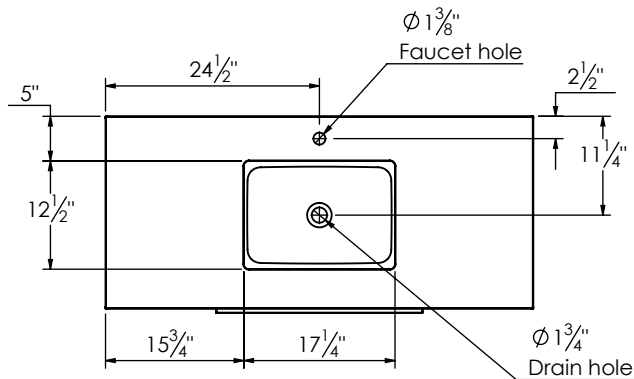

**TOP VIEW**

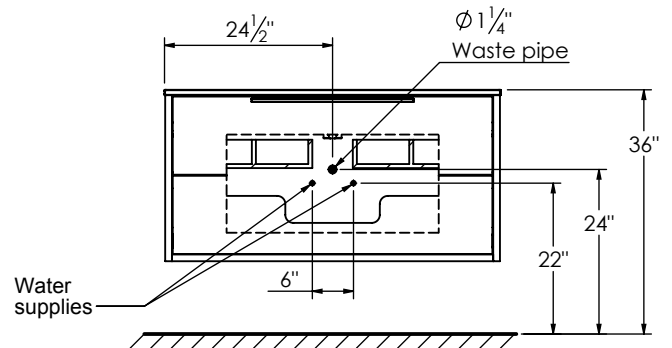

**ROUGH PLUMBING**

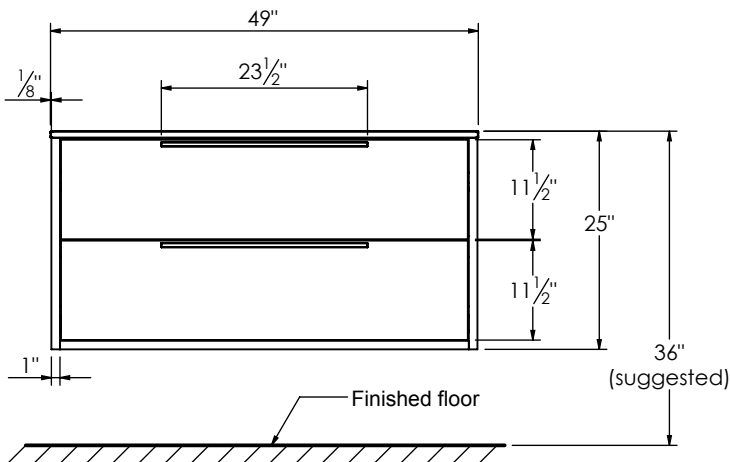

**FRONT VIEW**

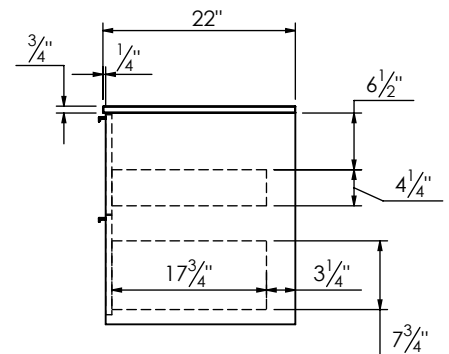

**SIDE VIEW**