

## SPEC SHEET

### PRODUCT DESCRIPTION

- Hudson 60 Double freestanding bathroom vanity
- Available in Natural Elm (36), Matte White (50), Rock Gray (52) and Natural Walnut (56) finish
- Cabinet is fully assembled
- Hardwood Plywood construction
- Soft close doors and (full extension) drawers
- Features 4 glass dividers in the top drawer
- Features 1 wood divider in the middle drawer
- Features 2 Internal wood shelf with plumbing cut out
- Solid Surface counter top with integrated basins in Matt White
- Solid Surface material is 38% polyester resin and 60% aluminum hydroxide powder
- Basin depth is 4 1/2"

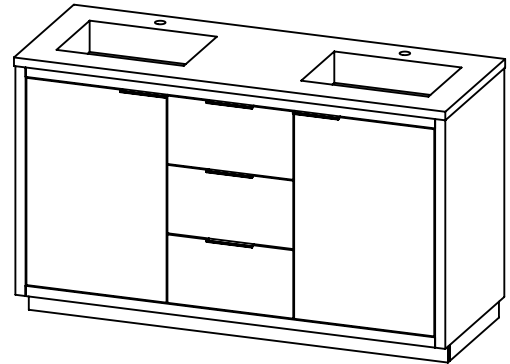

### ROUGHING-IN DIMENSIONS

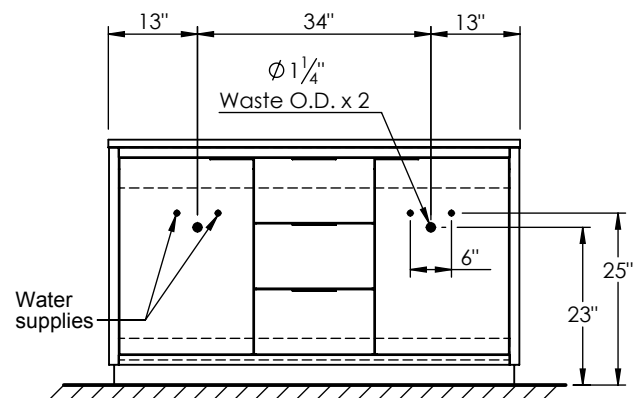
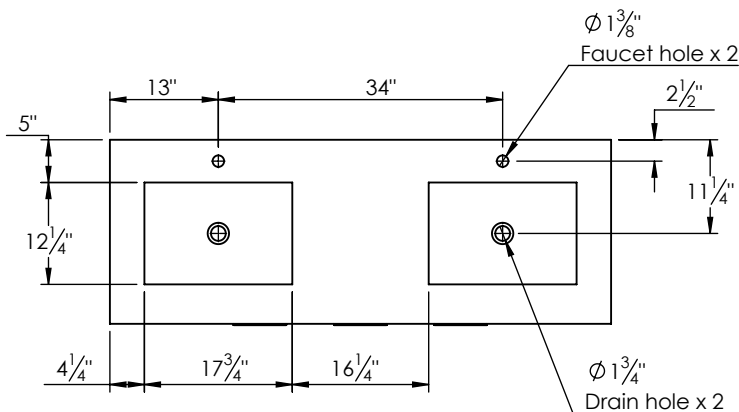
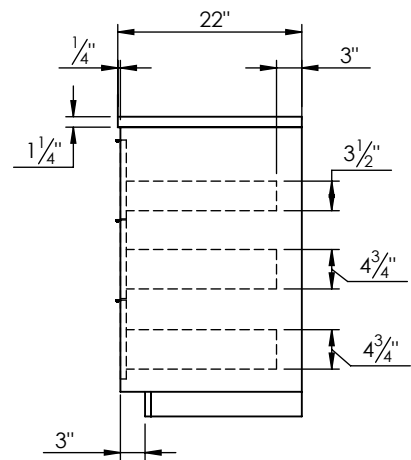
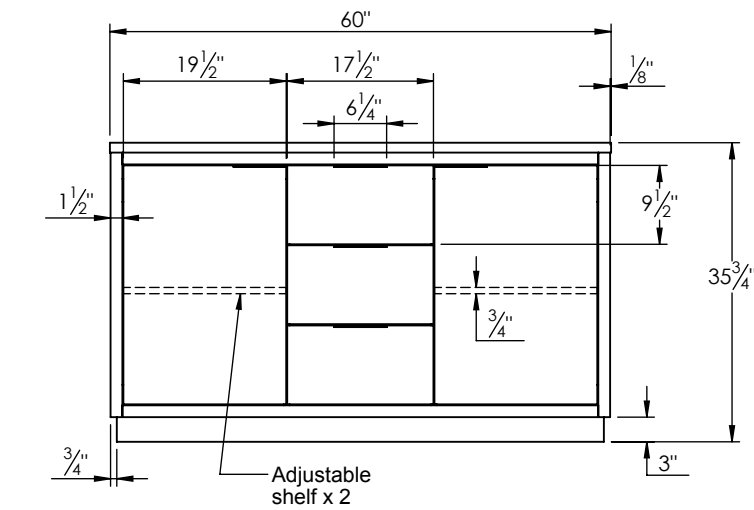

### ROUGH PLUMBING