

INSTALLATION MANUAL

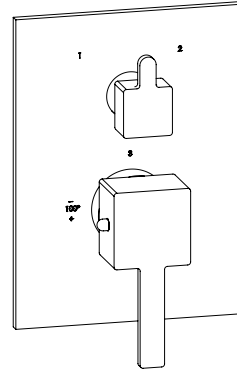
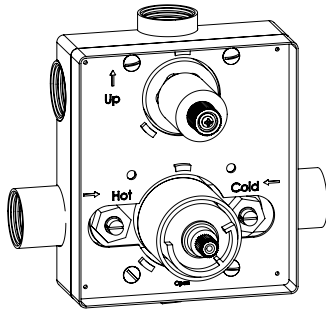

Compliance:
ASME A112.18.1
CSA B125.1

IMPORTANT CONSIDERATIONS

- This product and other additional shower components must be installed by a professional plumber who is experienced at installing custom shower sets.
- Read the complete installation manual thoroughly before beginning the install. Make sure you have gathered all of the necessary tools and components needed.
- To prevent scalding injuries, the maximum output temperature from the water heater shall not to exceed 120°F. In the state of Massachusetts the maximum output temperature shall not exceed 112°F.
- Excessive heat may damage the valve unit. Never solder directly onto the valve body.

TECHNICAL INFORMATION

- Factory-calibrated comfort setting at 100°F for the first stop position.
- Flow rate up to 5 gpm @ 60 psi for all outlets.
- Recommended water pressure is 20 - 80 psi.
- Recommended max hot water temperature is 120°F.
- Max tested water pressure is 145 psi.
- Max tested water temperature is 176°F.
- Built-in ceramic diverter for three individual functions and three closed functions.

Tools you may need

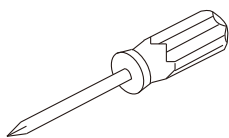

Flat and phillips
screwdriver

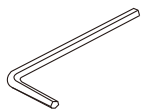

Hex allen key
(provided with trim set)

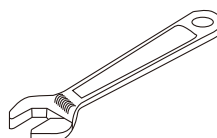

Adjustable wrench

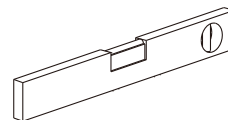

Spirit level



Teflon tape

1

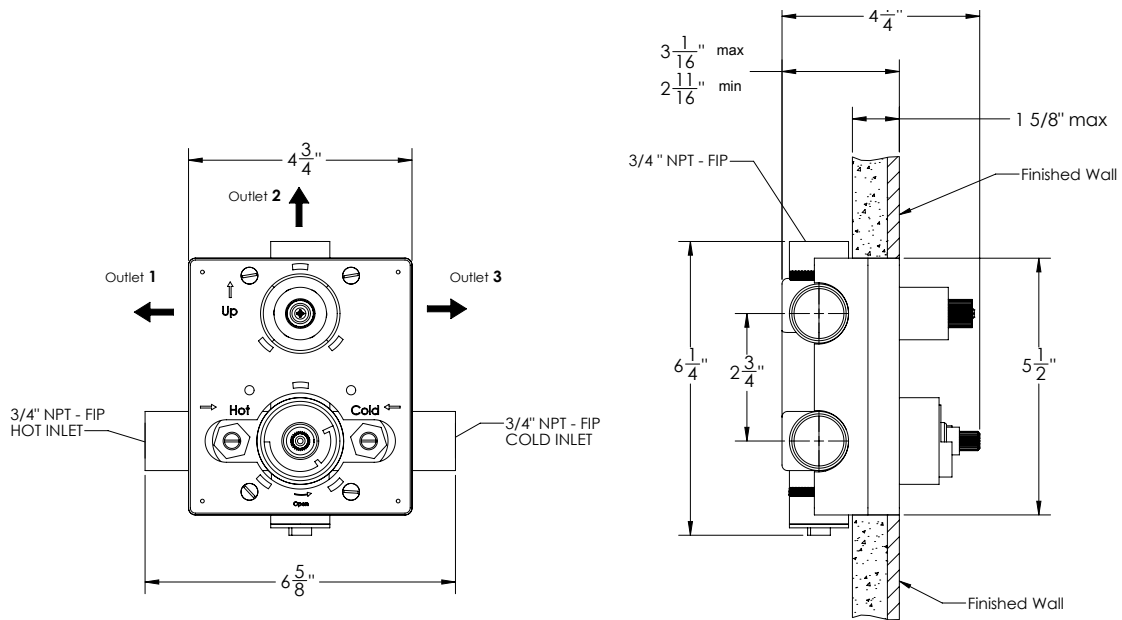

IS203 Rough valve

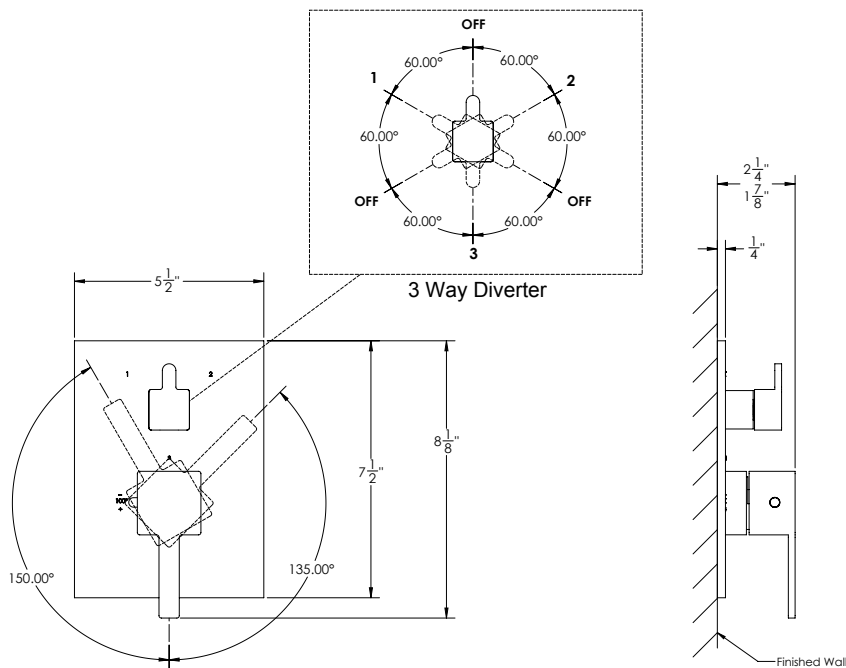

IS203-1-X Trim set

ROUGH-IN

- Prepare and measure the wall space for the rough valve installation according to specs.
- The back of the rough shower valve should be within 2 11/16" - 3 1/16" to the finished wall.

CAUTION: Failure to comply with the above mentioned dimensions will result in a failed installation.

HINT: When is all set and done the square plastic case from the valve should be flush with the finished tile/wall.

2

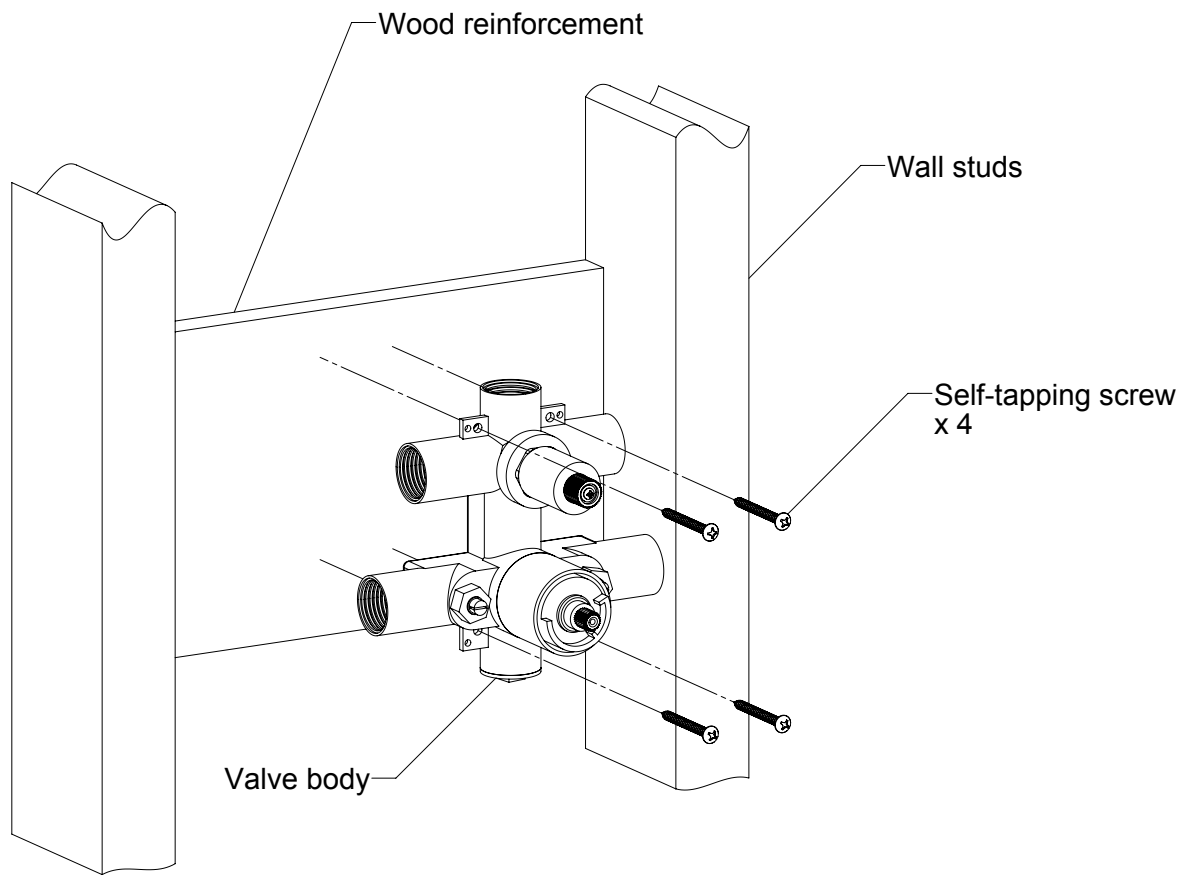

Fig #2

SECURE THE VALVE

- Build out an area of wood reinforcement in between wall studs.
- Remove plastic case from shower valve body.
- Fasten the shower valve body to the wood area using the self tapping screws.
- Re-install the plastic case onto the valve body.

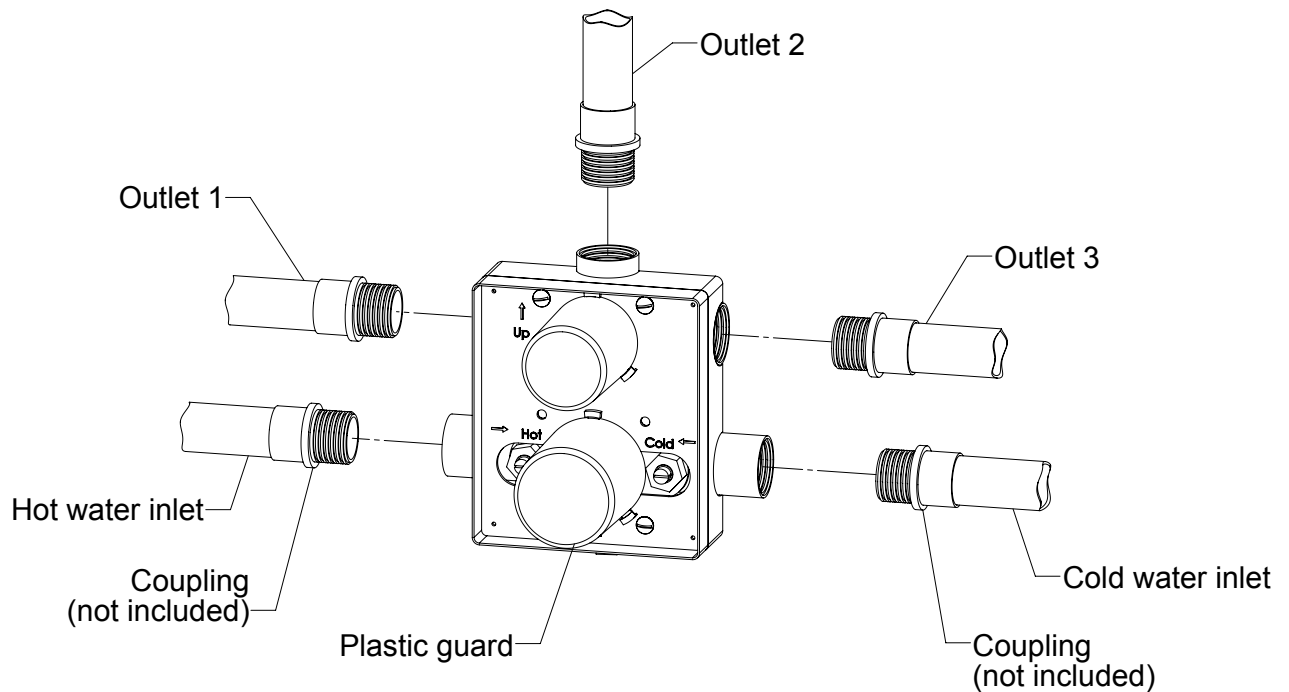

Fig #3

CONNECT THE VALVE

- Shut off the main water supply.
- Check the supply lines for damage. It is recommended to flush all pipes thoroughly before installation.
- Connect the hot and cold water supply as shown in fig #3.
- Connect the rest of the shower functions accordingly. Do not use the bottom outlet of the valve that is factory sealed.
- Turn water supply on and check for leaks.

CAUTION: Do not solder directly onto the valve body. Doing this will void your warranty and damage the valve.

HINT: If solder/brazing the fitting connections, pre-assembly hot & cold adapter fittings to copper piping. Using plumbers tape or equivalent to attach adapter/coupling to appropriate inlet port.

4

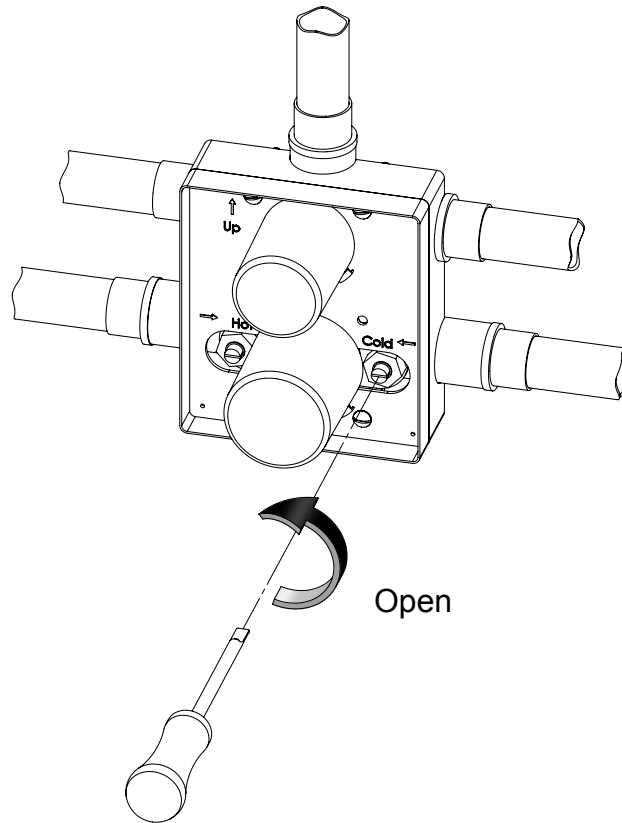

Fig #4

OPEN THE SERVICE STOPS

- The valve is equipped with service stops for your convenience.
- Using a flat head screwdriver, rotate counter-clock wise to fully open the service stops and allow flow into the system.
- Check for leaks at this time
- To close the service stops, rotate clock-wise

CAUTION: Do not force the service stops past its normal open/close travel. Doing so can harm the stop valve.

HINT: Open/close the service stop valve until reaching the natural stop.

5

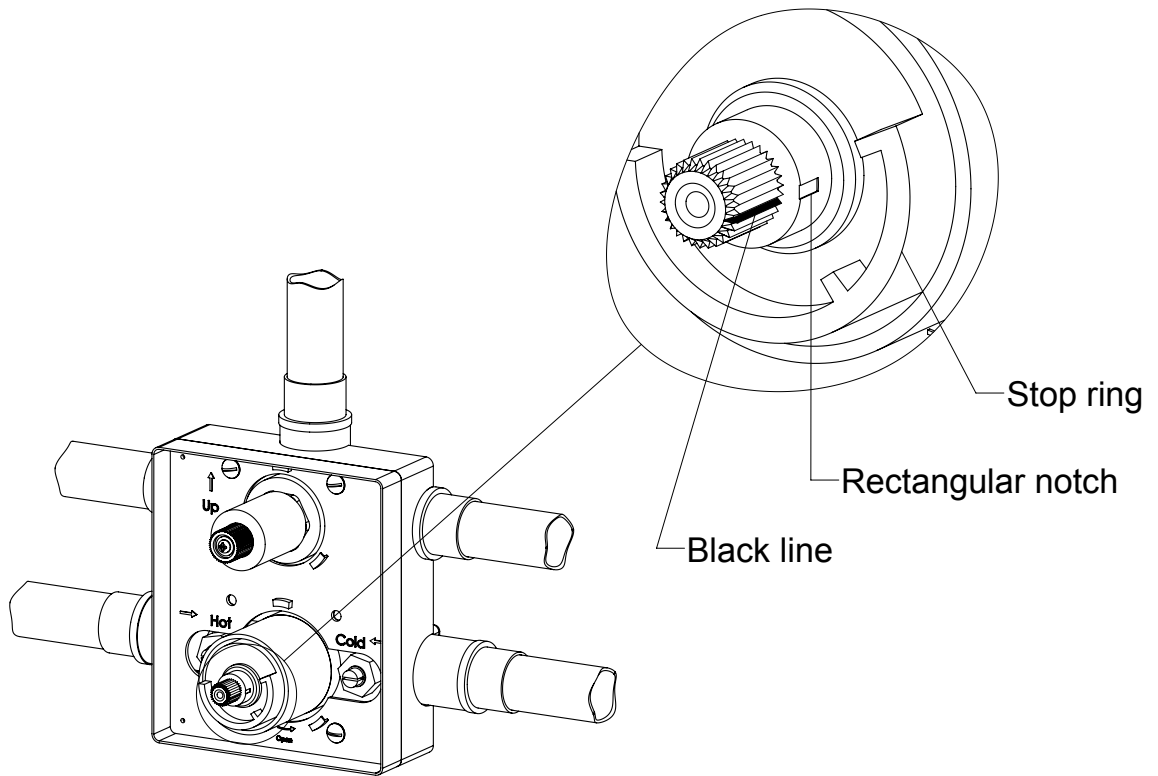

Fig #5

CALIBRATE THE VALVE

- Remove plastic guard from valve (see fig #3).
- The thermostatic cartridge is calibrated at factory setting for 100°F at the first stop position.
- To obtain proper calibration, the black line of cartridge stem should be in line with the rectangular notch of the cartridge body.
- At the same time check the proper alignment of the stop ring as shown in fig #5.

CAUTION: If the valve is not properly calibrated, incorrect temperature readings will occur.

HINT: If not ready to go to the next step or if the finished wall is not ready yet, re-install the plastic guard to protect the valve finish.

6

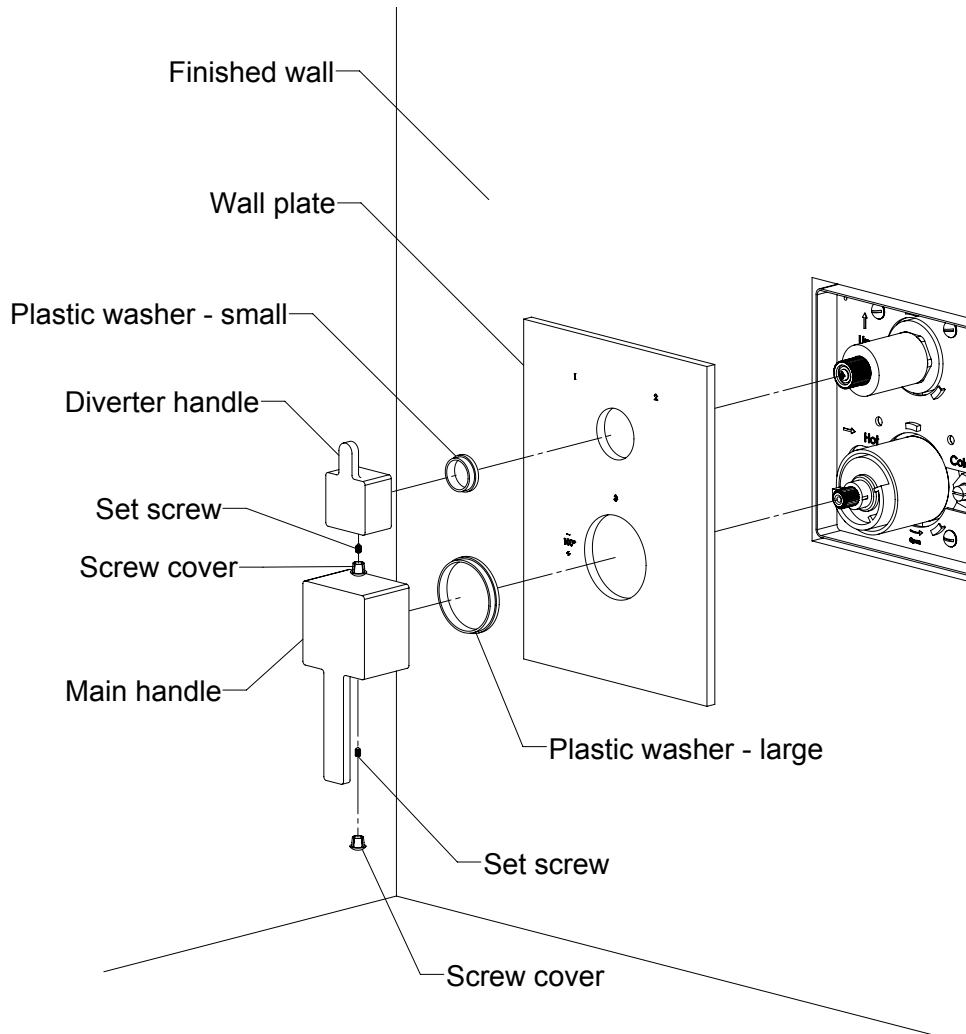

Fig #6

INSTALL THE TRIM SET

- Carefully insert the wall plate onto the valve shaft until it's flush against the finished wall.
- Insert the main handle, all the way in, onto the thermostatic valve stem. The lever must be pointing down as shown in fig #6.
- Tighten the set screw using the allen key provided and insert the screw cover into place.
- With the diverter at the off position, insert the diverter handle onto the diverter stem extender. The small lever must be pointing up as shown in fig #6.
- Tighten the set screw using the allen key provided and insert the screw cover into place.

HINT: Use clear silicone to hold the wall plate in position.

7

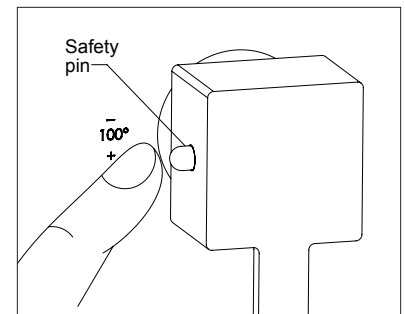
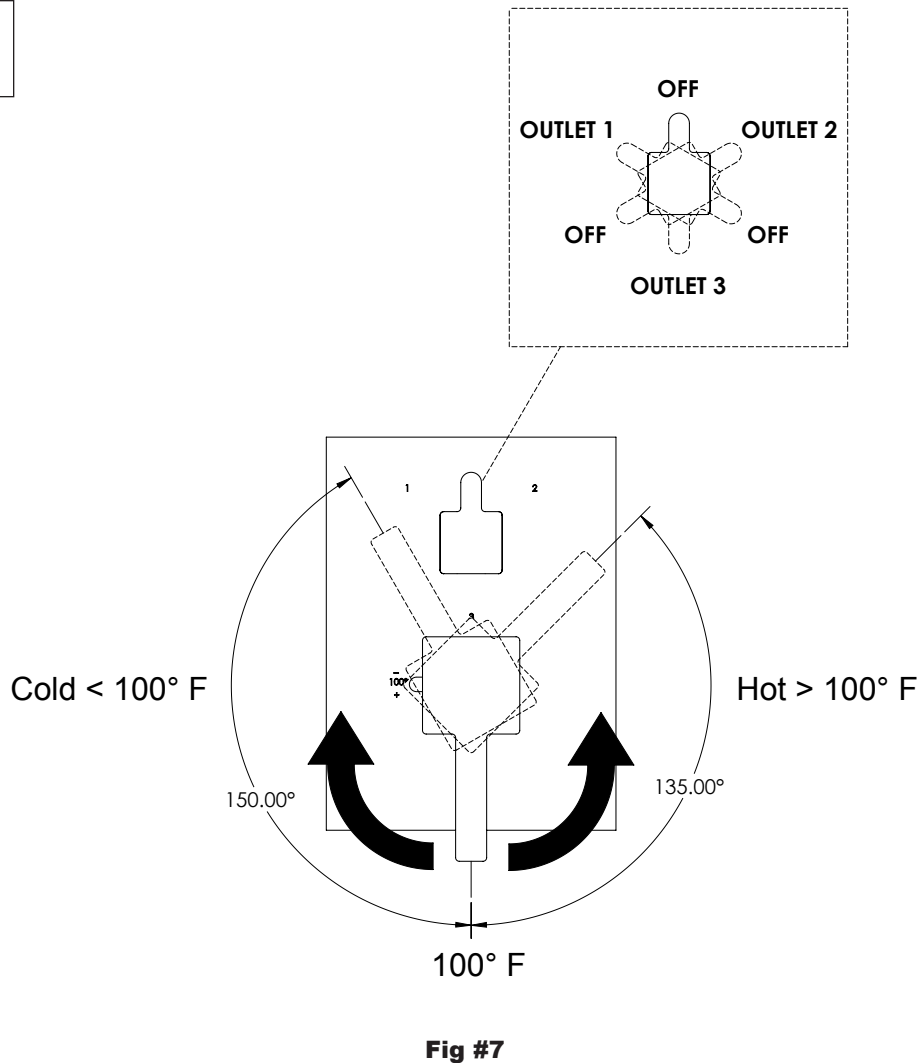

Fig #8

TEST THE DIVERTER

- Rotate the diverter left or right to obtain the desired position of use.
- The diverter has three 'on' positions and three 'off' positions as shown in fig #7.

HINT: If the numbers on the wall plate do not correspond with the desired shower function, re-install the diverter handle after making the necessary adjustments/rotations to the diverter itself. Refer to step 6 if re-installing the diverter handle.

TEST THE VALVE

- Operate the valve to test the cold and hot water. Rotate left for cold and right for hot.
- The safety pin must be pressed when operating the valve towards the right side past the initial stop (or past 100°F). See fig #8.
- Only operate the valve within the operational range shown in fig #7.

CAUTION: Never force the handle past the operational range. Doing so will damage the thermostatic cartridge.

HINT: At the end of each use return the handle to the original position (pointing down or 6 o'clock).

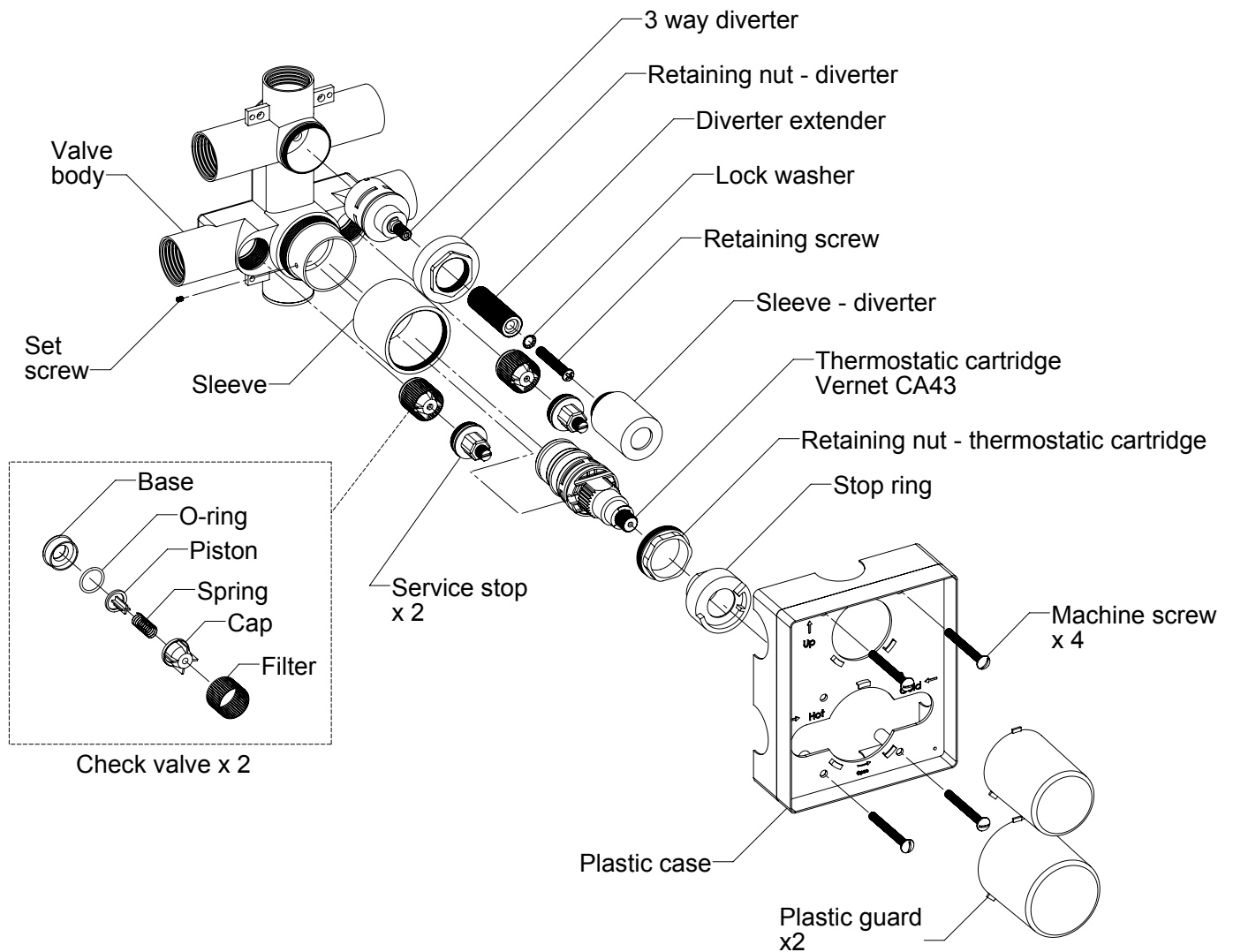

Fig #9

THERMOSTATIC CARTRIDGE REMOVAL / INSTALLATION / MAINTENANCE

- Close both service stops using a flat screw driver.
- Carefully remove sleeve by rotating counter-clock wise.
- Pull out the stop ring by hand or needle plier.
- Unscrew the retaining nut using an adjustable wrench.
- Remove the set screw using an allen key.
- Carefully remove the cartridge by pulling straight out.
- Clean the cartridge filters and re-install or replace with a new cartridge.
- Re-open the service stops.

This valve has screens to prevent dirt from damaging the thermostatic cartridge. Clogged screens can reduce the flow and decrease efficiency of temperature mixing by the valve.

HINT: When re-installing, pay close attention to the orientation of the thermostatic cartridge and stop ring as shown in fig #9.

DIVERTER CARTRIDGE REMOVAL / INSTALLATION / MAINTENANCE

- Close both service stops using a flat screw driver.
- Carefully remove diverter sleeve by rotating counter-clock wise.
- Unscrew the retaining nut using an adjustable wrench.
- Carefully remove the diverter cartridge by pulling straight out.
- Clean the cartridge openings and re-install or replace with a new cartridge. Refer to fig #9.
- If replacing with a new diverter cartridge, remove the extender from old cartridge and re-install onto the new one.

SERVICE STOP REMOVAL / INSTALLATION / MAINTENANCE

- Close the main water supply from house or building.
- Unscrew the service stop using an adjustable wrench.
- Remove check valve.
- Clean filter and re-install or replace with a new check valve.
- Re-install service stop and open the main water supply.
- Refer to fig #9.

TROUBLE SHOOTING

Problem	Cause	Action
Insufficient water pressure.	Service stops are not fully open. Cartridge has a dirty filter.	Open both service stops fully. Clean or replace cartridge.
Insufficient or lack of hot water.	Water heater might be set too low. Valve is not properly calibrated.	Increase the water heater temperature. Calibrate valve as shown is step 4.
Cartridge is hard to turn or water leaks from the handle.	The cartridge filter is dirty or worn out.	Clean or replace cartridge.
Incorrect temperature reading.	Valve is not properly calibrated. Hot and cold supply are reversed.	Calibrate valve as shown is step 4. Correctly re-install the water supplies.

CLEANING AND CARE

Clean the faucet often with a soft cloth to keep it looking like new. For heavy cleaning you can use mild liquid detergents or non-abrasive liquid polisher. Rinse with water and dry with a soft cloth. Avoid abrasive cleaners, steel wool and harsh chemicals as these will dull the finish and void your warranty.

LIMITED LIFETIME WARRANTY

INOLAV provides its customers with an extensive warranty as a result of our excellent workmanship and high quality components used in our products.

Mechanical warranty: A limited lifetime warranty is provided on all mechanical parts to be free from manufacturing defects in materials and workmanship under normal use for as long as the original purchaser owns their home.

Finish warranty: A 5-year warranty is provided on all INOLAV faucet finishes to the original purchaser against manufacturing defects in materials and workmanship.

At its sole discretion, INOLAV will repair or replace any part or finish that proves to be defective in material and/or workmanship under normal installation, use and service.

This warranty is extended to the original consumer owner, but does not cover installation or any other labor charges. In no event shall INOLAV be liable for any incidental, consequential or special damages, installation cost, labor, travel time, freight costs incurred, lost profits, or contingent liabilities. INOLAV makes no representation that its products comply with any or all local building or plumbing codes. It is the consumer's responsibility to determine local code compliance.

For questions please call us at 1-855 472 4304 or visit our website at www.inolav.com